

※ 거미 로봇 조립 매뉴얼
 모델명 : [18족 거미로봇]

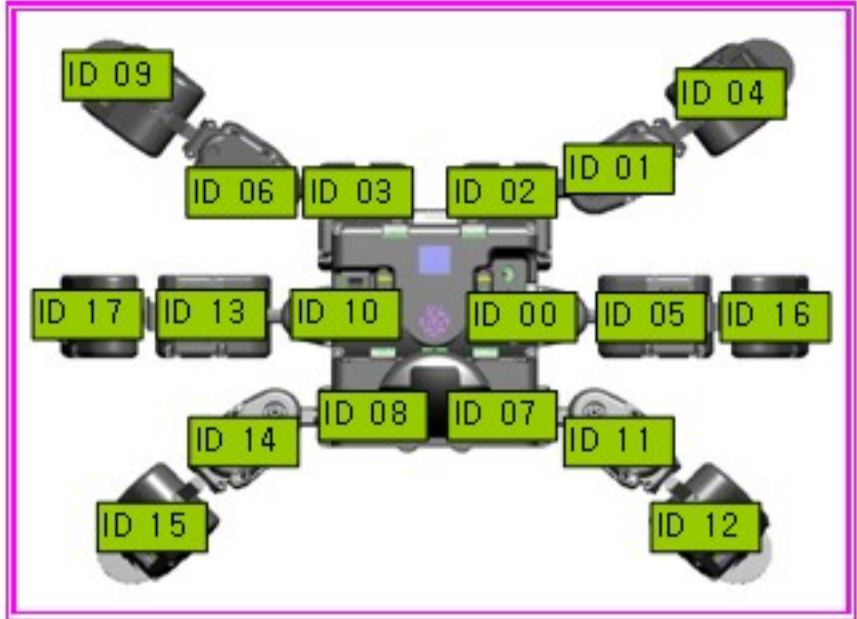

Part List



Body Frame e x 1



Control Box x 1



Head Part x 1



wCK 모듈 x 18



wCK 모듈 Cable x 18



Joint 1 x 2



Joint 2 x 4



Joint 6 x 4

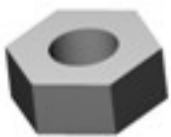

Nut x 54



B6 x 4



Joint 11 x 6



Joint 10 x 2



B8 x 4



B12 x 16



B16 x 24



B40 x 22

STEP 01

머리 조립

Bolt M2x6L - 4ea

Nut M2 - 4ea

Bolt M2x12L-2ea

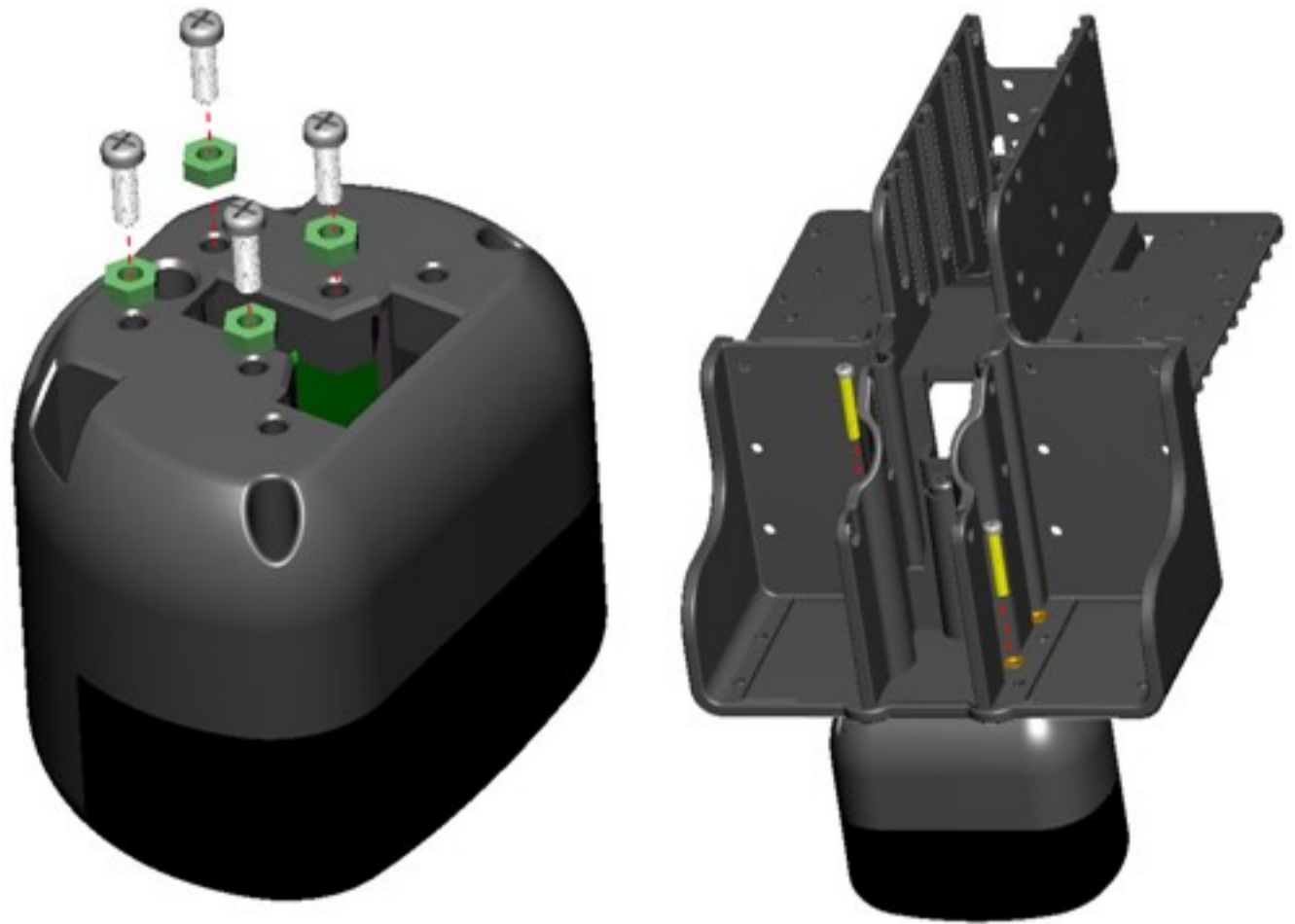

STEP 02

왼쪽다리

Bolt M2x40L-3ea

Nut M2 - 3ea

Bolt M2x8L-1ea

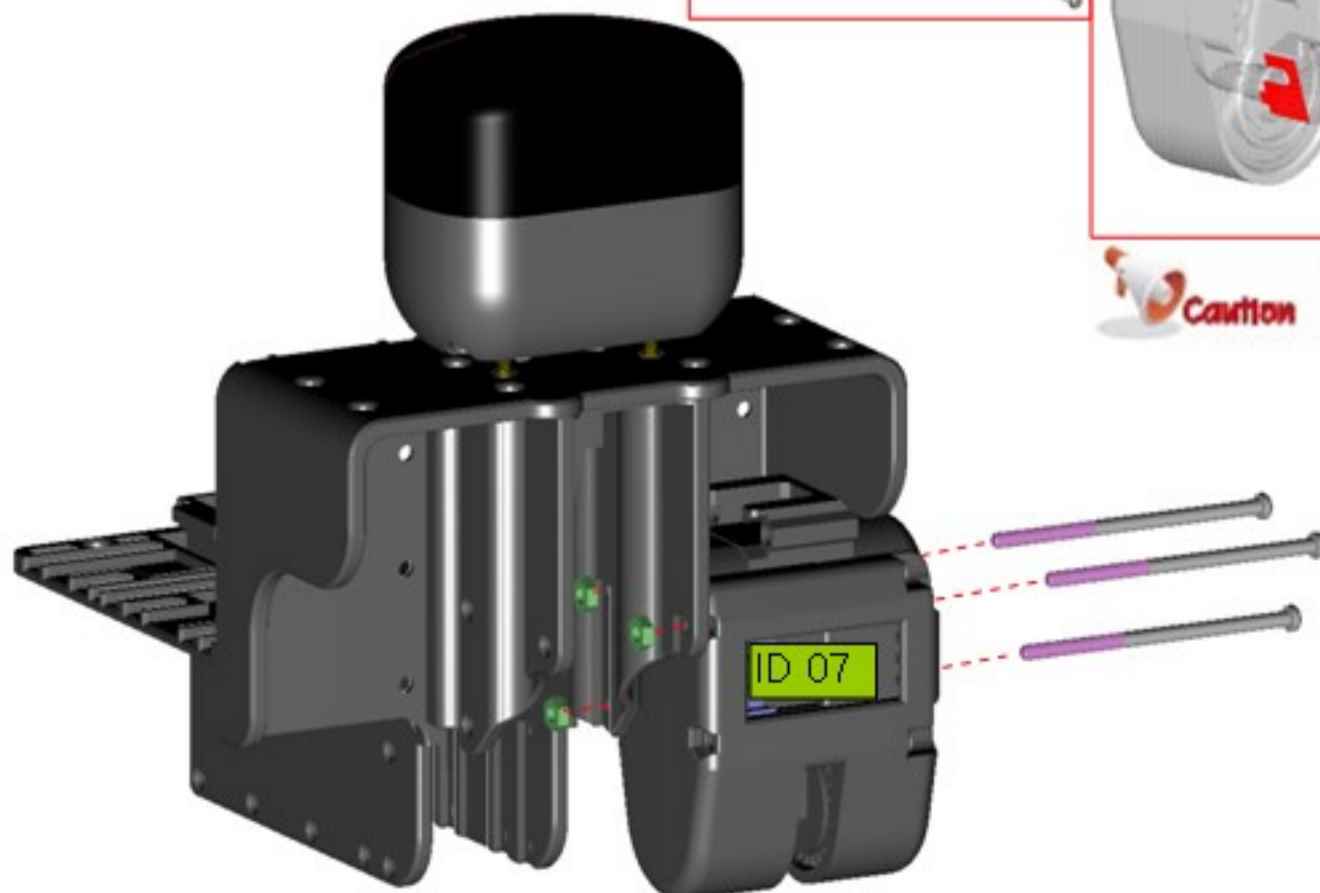

조인트 결합 시 각도가
매우 중요합니다.

STEP 03

왼쪽다리

- Bolt M2x16L-4ea
- Nut M2 - 4ea
- Bolt M2x12L-2ea

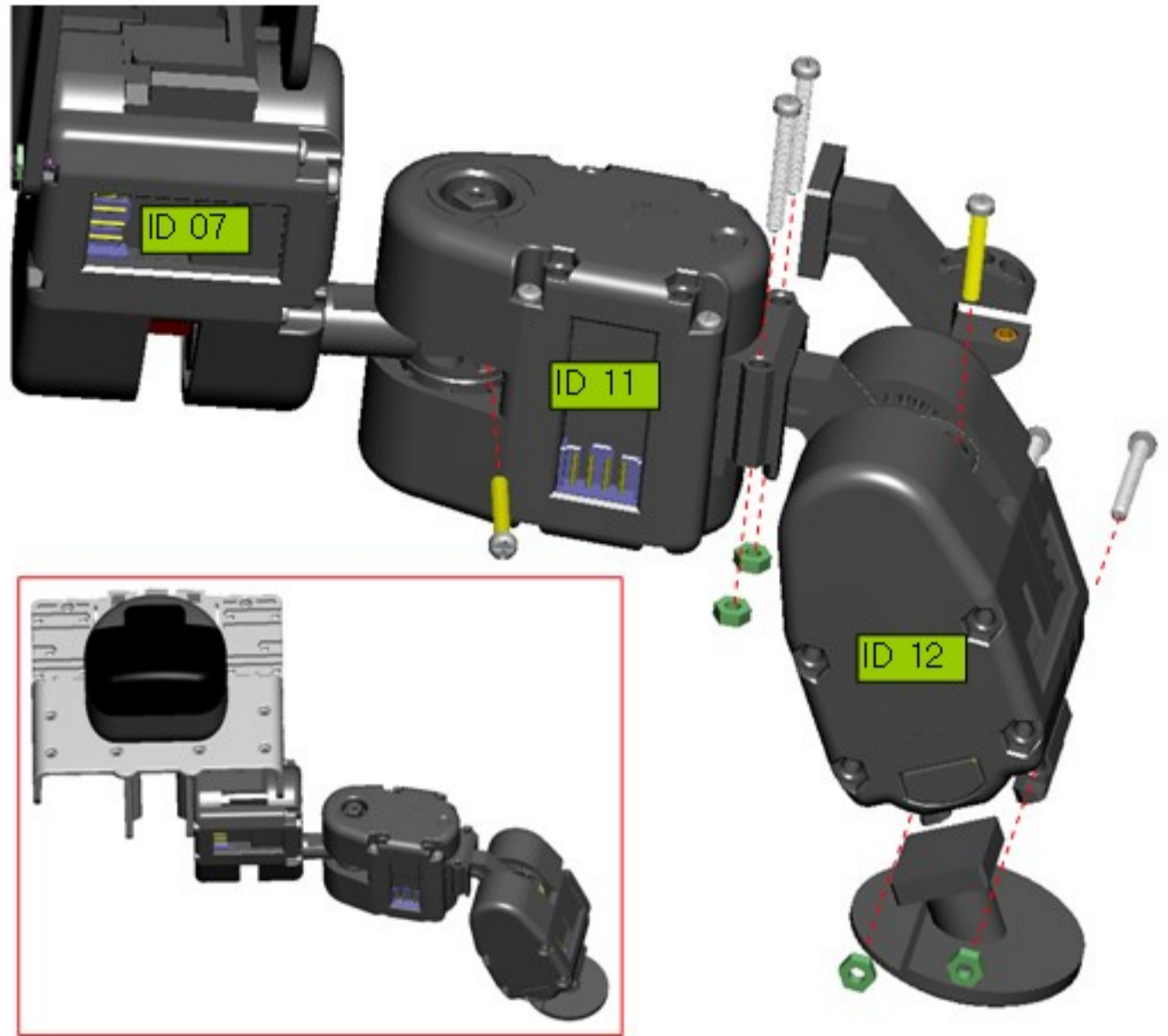

STEP 04

오른쪽다리

- Bolt M2x40L-3ea
- Nut M2 - 3ea
- Bolt M2x8L-1ea

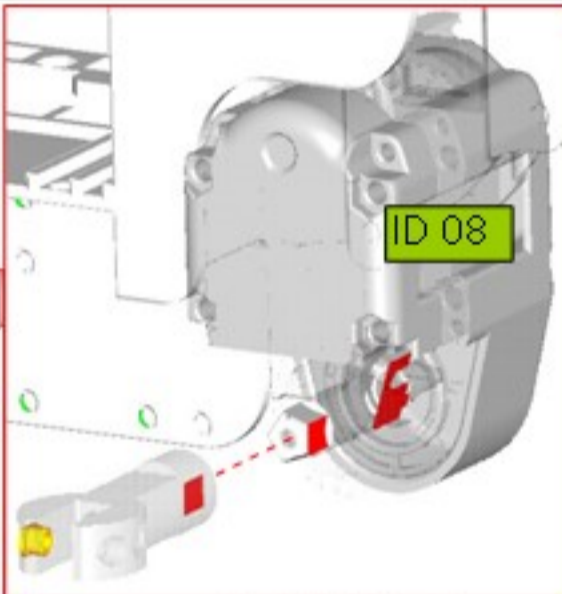

Caution 조인트 결합 시 각도가 매우 중요합니다.

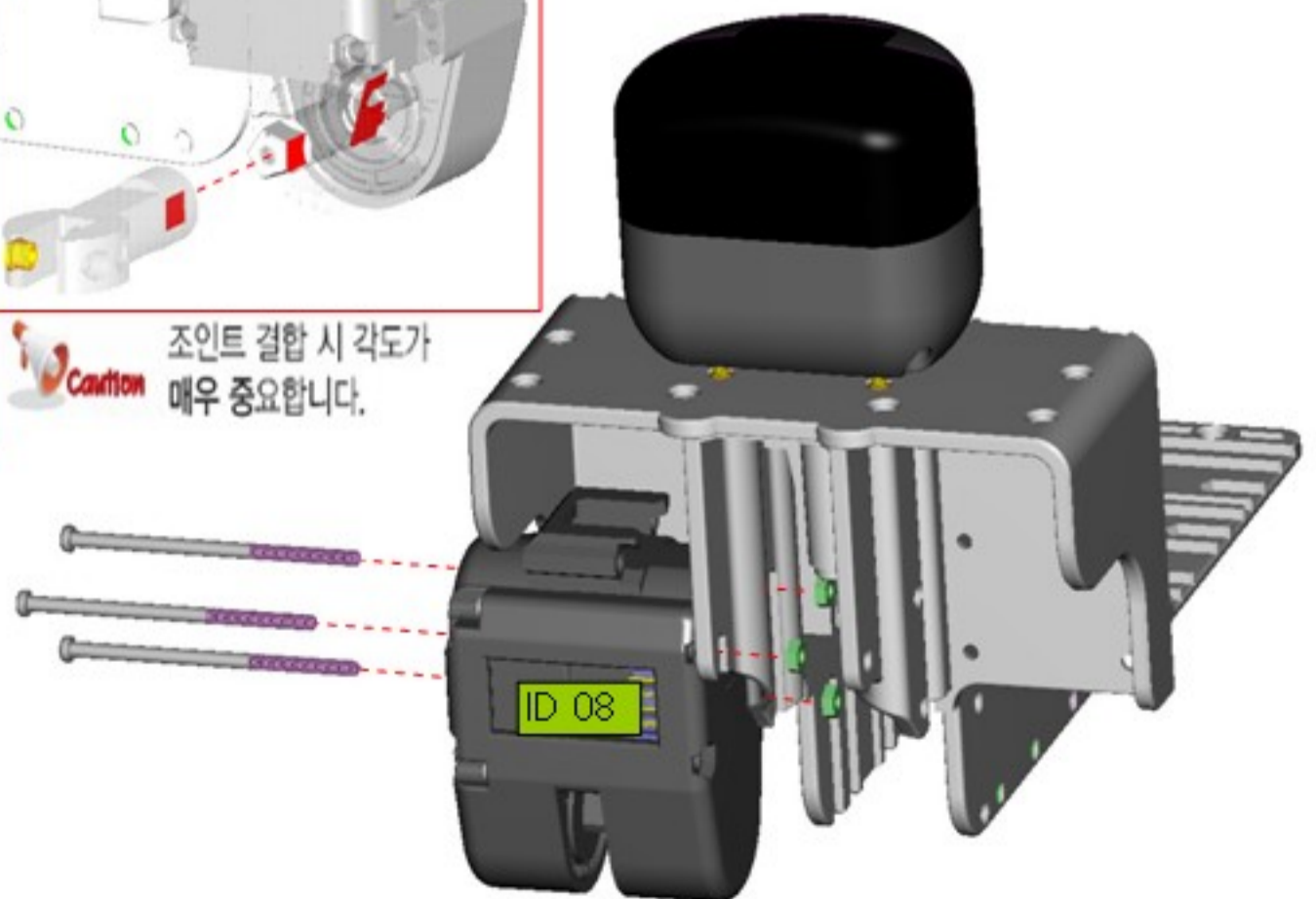

STEP 05

오른쪽다리

Bolt M2x16L-4ea
Nut M2 - 4ea
Bolt M2x12L-2ea

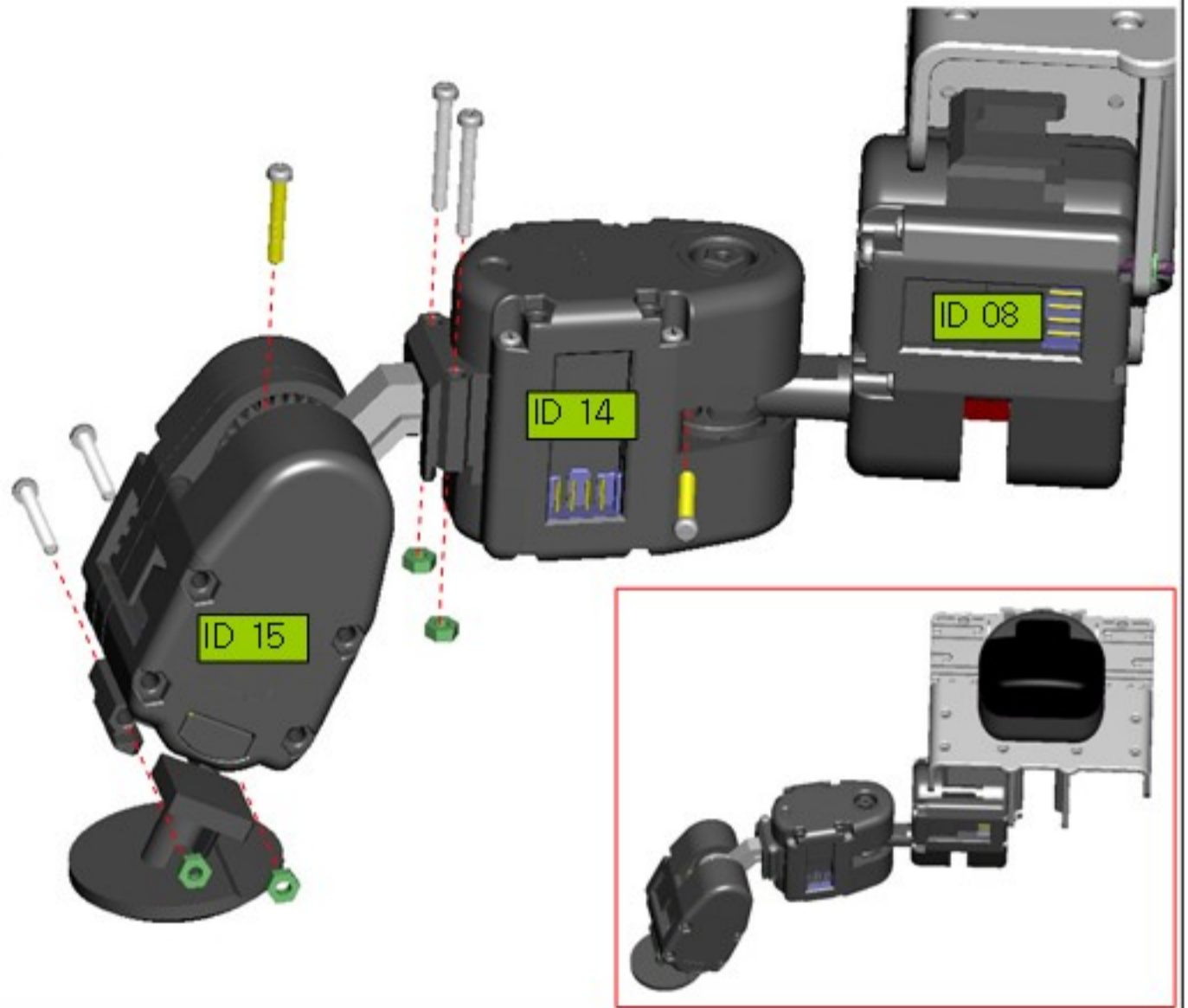

STEP 06

중앙 다리

Bolt M2x40L-3ea
Nut M2 - 11ea
Bolt M2x12L-3ea
Bolt M2x16L-4ea

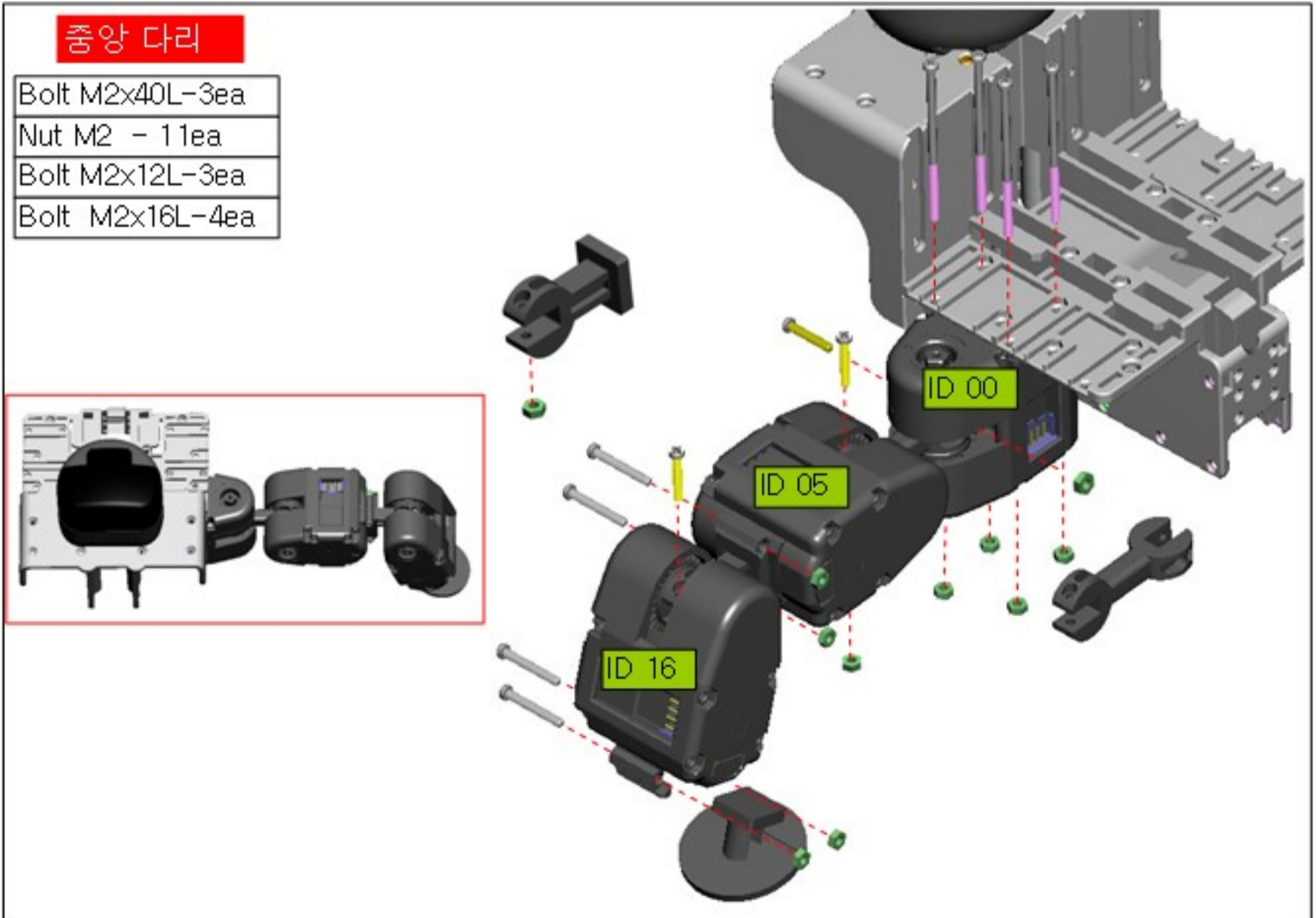

STEP 07

중앙 다리

Bolt M2x40L-4ea

Nut M2 - 11ea

Bolt M2x12L-3ea

Bolt M2x16L-4ea

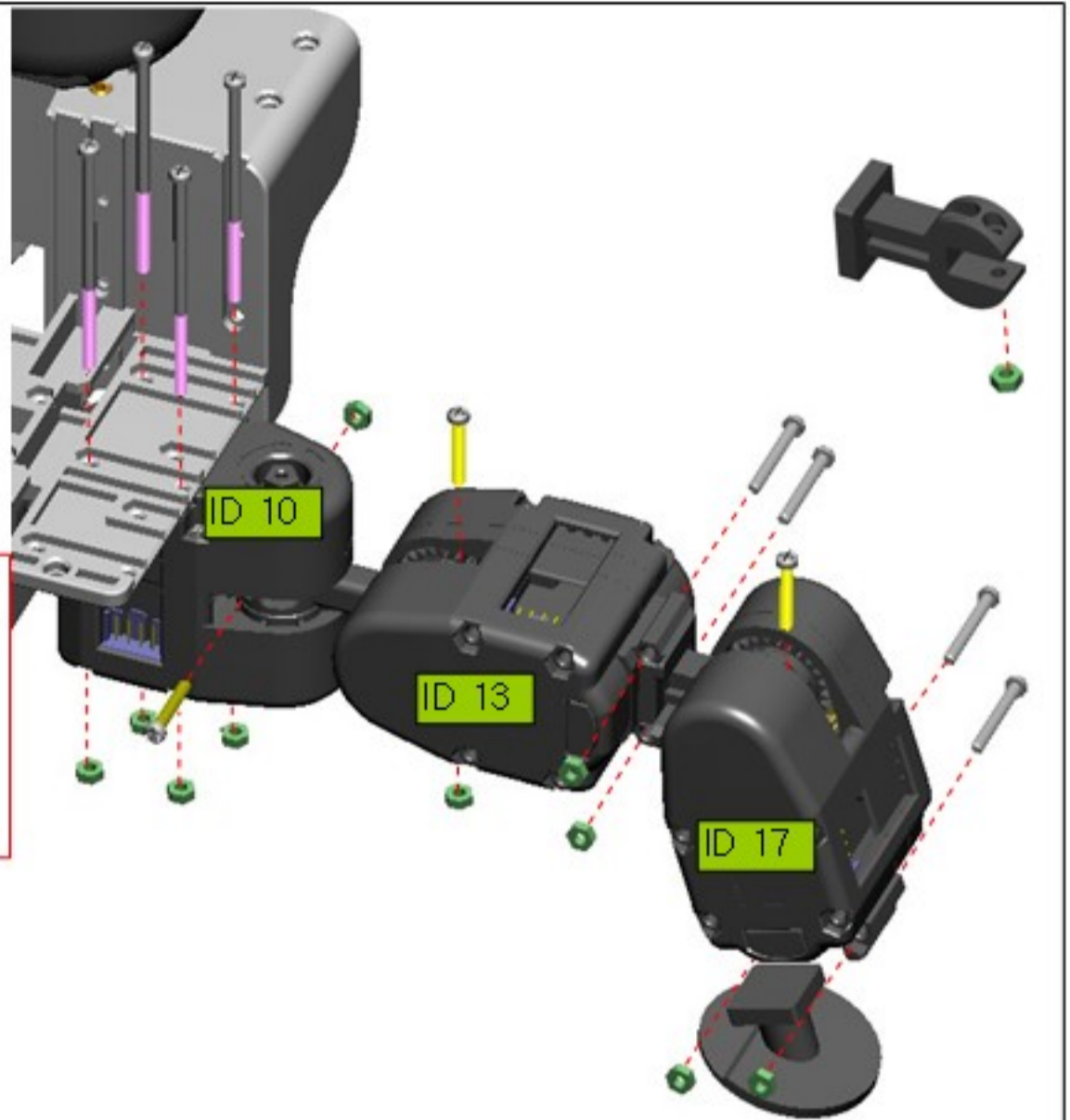

STEP 08

왼쪽 다리

Bolt M2x40L-4ea

Nut M2 - 4ea

Bolt M2x8L - 1ea



조인트 결합 시 각도가
매우 중요합니다.

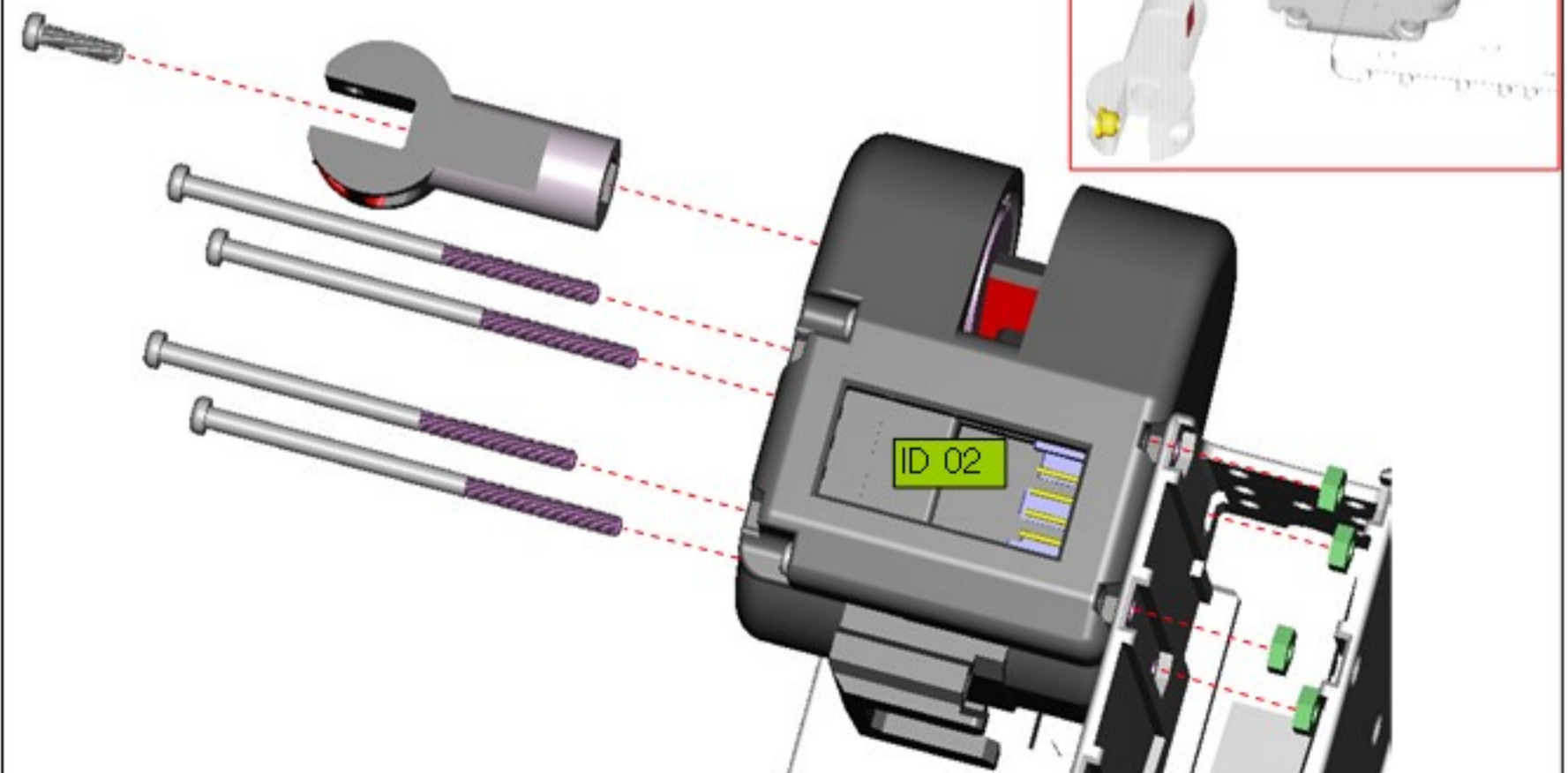
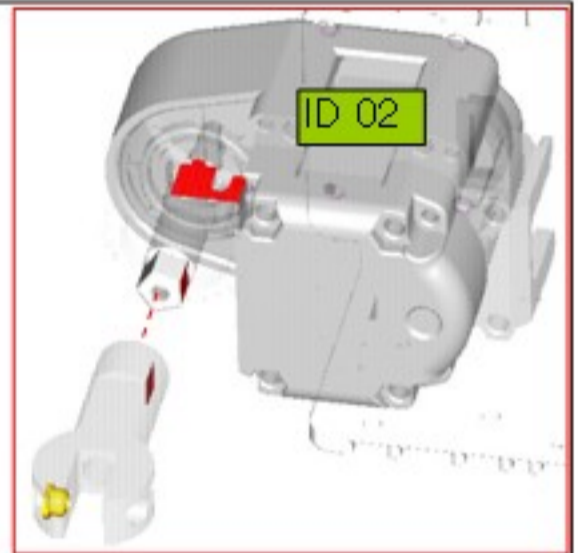

STEP 09

왼쪽 다리

Bolt M2x16L-4ea
Nut M2 - 4ea
Bolt M2x12L-2ea



STEP 10

오른쪽다리

Bolt M2x40L-4ea
Nut M2 - 4ea
Bolt M2x8L - 1ea



조인트 결합 시 각도가
매우 중요합니다.

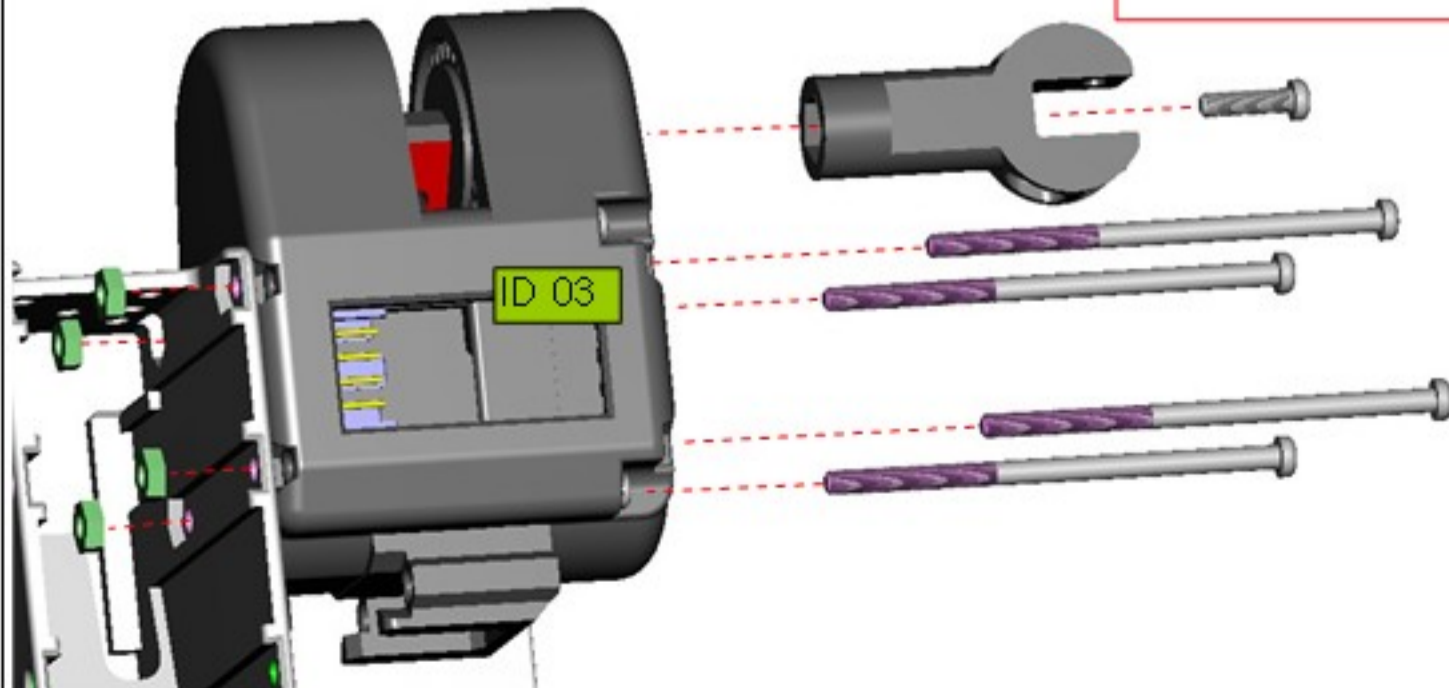
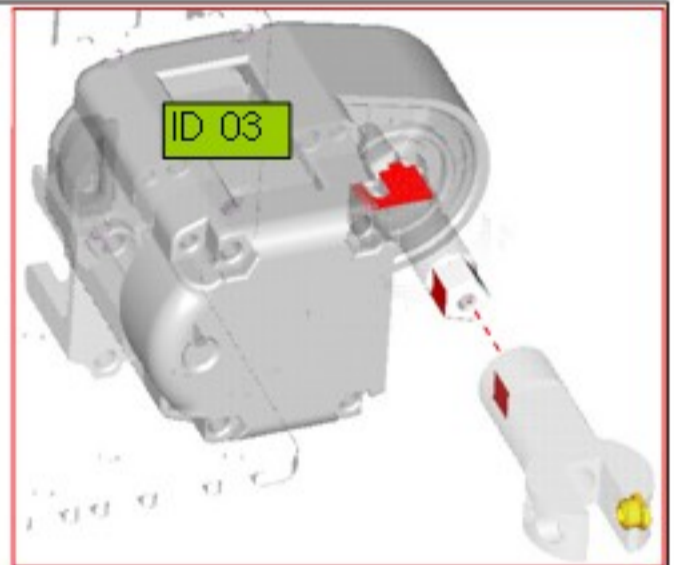

STEP 11

오른쪽다리

Bolt M2x16L-4ea

Nut M2 - 4ea

Bolt M2x12L-1ea

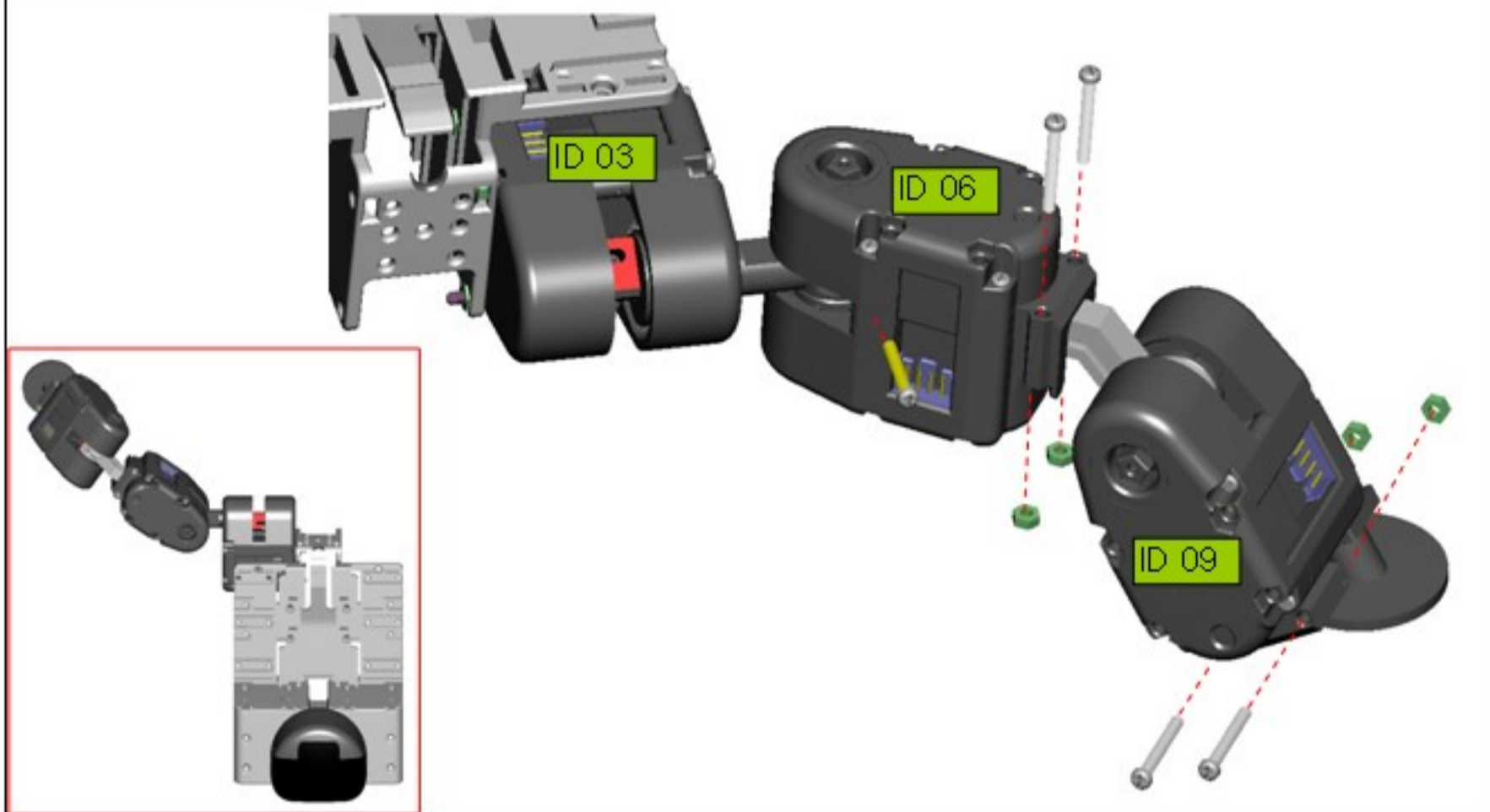

STEP 12

RBC 조립

